

DESIGN OF RC STRUCTURES

STAFF NAME : Mr.R.Yuvaraja  
SUB NAME : Design of Reinforced Concrete & Brick Masonry Structures  
CLASS : IV Year / VII SEM

TEXT BOOK:

1. P.C.Varghese, “ Limit State Design of Reinforced Concrete”,Prentice Hall of India, Pvt, Ltd, New Delhi.
2. Krishna Raju.N, “Design of Reinforced Concrete Structures” , CBS Publishers & Distributors, New Delhi.

References:

1. Dr.B.C.Punmia, Ashok Kumar Jain, Arun Kumar Jain, “ RCC Designs”, Laxmi Publications, New Delhi.
2. Jain.A.K, “ Limit State Design Of RC structures”, Nemchand.
3. Unnikrishna pillai.S, Devadas Menon, “ reinforced Concrete Design”, tata McGraw- Hill Publishing Company Ltd, New Delhi.
4. Ramamrutham” Design of reinforced Concrete Structures,” Dhanpat rai publishing Company, NewDelhi

**CE 2401 - DESIGN OF REINFORCED CONCRETE & BRICK MASONRY STRUCTURES**

**UNIT -1 RETAINING WALL**

**EXPECTED TWO MARKS**

1. Define Retaining Wall

A retaining wall is a wall, often made of concrete, built for the purpose of retaining, or holding back, a soil mass (or other material).

2. What are the Types of Retaining Walls?

Gravity wall: A simple retaining wall depending on its weight to achieve its stability.

Cantilever wall: a taller wall with extended toe and heel to offset the large lateral pressure tending to overturn the wall. A cantilever wall has part of the base extending underneath the backfill, and the weight of the soil above this part of the base helps prevent overturning.

Other types: retaining wall with anchor retaining wall with stepped back

3. What are the types of Retaining Walls? With diagram

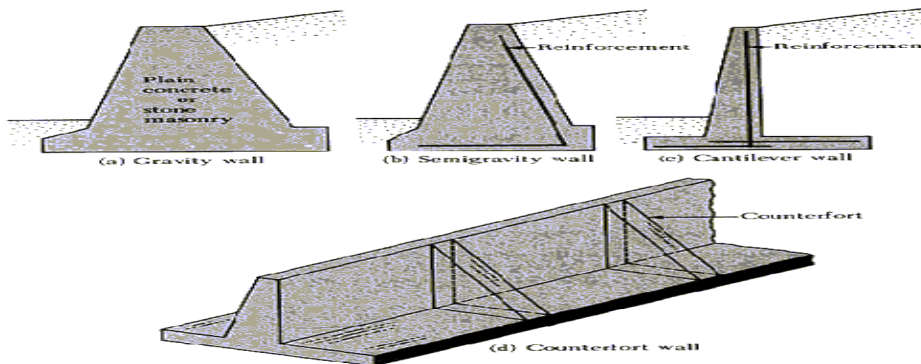

4. What are the structural components of Retaining Walls?

Base, heel, toe, Stem, backfill: The material placed behind a retaining wall.

5. What are three earth pressures? Explain Earth Pressure at Rest

Active earth pressure (the earth pressure exerted on the wall, when the wall moves away from the backfill). Passive earth pressure (the earth pressure exerted on the wall when the wall moves toward the soil).

6. Define factor of safety. What are the factors of safety available in Retaining Walls?

1. Factor of safety against sliding = 1.5 (if the passive earth pressure of the soil at the toe in front of the wall is neglected)
2. Factor of safety against sliding=2.0 (if the passive earth pressure of the soil at the toe in front of the wall is included)
3. Factor of safety against overturning = 1.5 (granular backfill soil)
4. Factor of safety against overturning = 2.0 (cohesive backfill soil)
5. Factor of safety against bearing capacity failure =3.0

7. Explain shear key? And its condition

It is advantageous to provide a shear key just below the stem so that the reinforcement can be extended in to shear key. Condition: Factor of safety against sliding by the frictional force will not be sufficient

8. Define Active and Passive Earth Pressure. (May 2011)

Active Earth Pressure: It is the pressure that at all times are tending to move or overturn the retaining wall”

Passive Earth Pressure: “It is reactionary pressures that will react in the form of a resistance to movement of the wall.

9. What are the Effects of Active and Passive Earth Pressure?

Active Earth Pressure:

It is composed of the earth wedge being retained together with any hydrostatic pressure caused by the presence of groundwater. This pressure can be reduced by:

The use of subsoil drainage behind the wall.

Inserting drainage openings called weep holes through the thickness of the stem to enable the water to drain away.

Passive Earth Pressure

It builds up in front of the toe to resist the movement of the wall if it tries to move forward.

This pressure can be increased by enlarging the depth of the toe or by forming a rib on the underside of the base.

10. What are the factors to be considered while designing the Retaining Walls?

- ✓ Overturning doesn't occur
- ✓ Sliding doesn't occur
- ✓ The soil on which the wall rests mustn't be overloaded
- ✓ The materials used in construction are not overstressed.

11. What are the forces or pressure that has to be calculated while designing the Retaining Walls?

- ✓ Height Of Water Table
- ✓ Nature & Type Of Soil
- ✓ Subsoil Water Movements
- ✓ Type Of Wall
- ✓ Material Used In The Construction Of Wall

12. What are types of gravity Retaining Walls?

- a) Massive Gravity Wall
- b) Counter fort Wall
- c) Cantilever Gravity Wall

13. Write down the formula for Factor of Safety of Retaining Walls?

Hence the factor of safety can be expressed by the relation,  
 $FOS = (0.9 \text{ stability force or moment} / \text{destabilising force or moment}) \geq 1.4$   
 The factor of safety against overturning is expressed as  
 $(FS)_{\text{overturning}} = (0.9Ms / Mo) \geq 1.4$

14. Draw the effective surcharge on a level back fill in Retaining Walls?

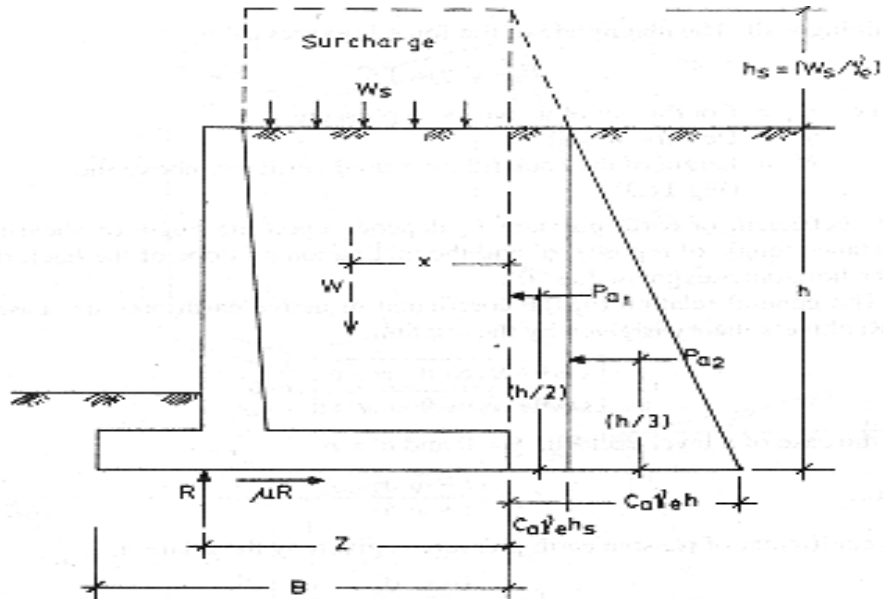

15. Write down the formula for Factor of Safety against sliding of Retaining Walls?

$$F = \mu R$$

16. Draw the Retaining Walls? And explain about passive pressure due to shear key?

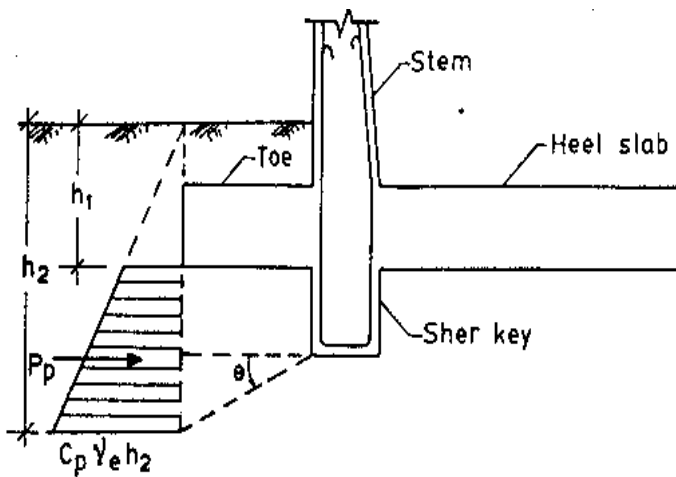

**Passive Pressure Due to Shear Key**

17. Draw the Retaining Walls with dimensioning?

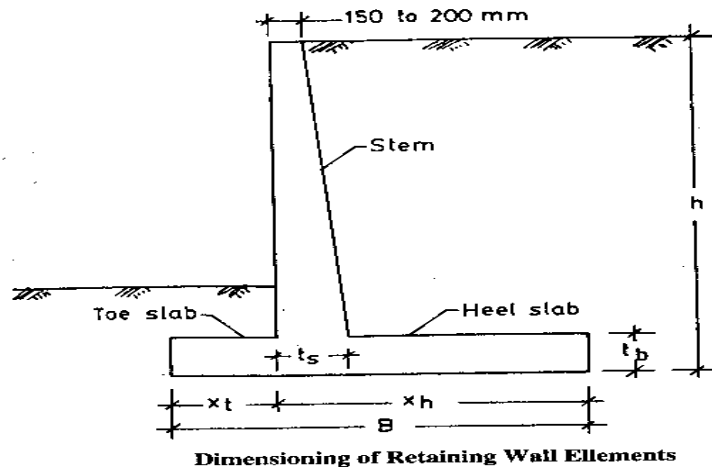

18. Write down the formula for finding minimum depth of foundation in Retaining Walls?

$$\text{Minimum depth of Foundation} = \left( \frac{p}{\gamma_s} \right) \left[ \frac{1 - \sin \phi}{1 + \sin \phi} \right]^2$$

19. Write down the formula for finding Active and Passive Earth Pressure?

$$C_a = 1 - \sin \phi / 1 + \sin \phi$$

$$C_p = 1 + \sin \phi / 1 - \sin \phi$$

20. Draw the deformation characteristics of Retaining Walls?

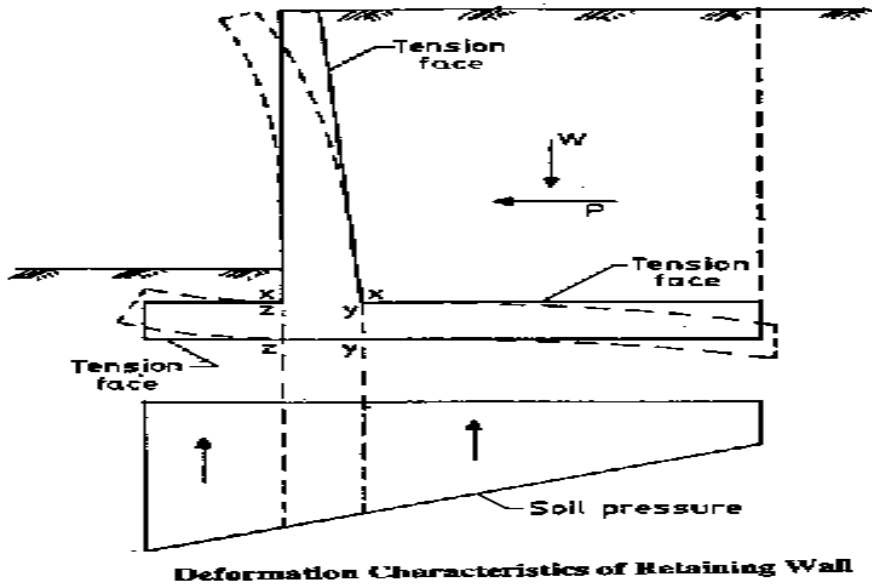

21. What are the total pressures of Retaining Walls?

- Case (I) Walls with vertical face on the earth side and the retained earth level
- Case (ii) surcharged Retaining Wall with vertical face on the earth side
- Case (iii) Retaining Wall with a sloping back
- Case (IV) Retained earth level, earth subjected to super load

22. What are the various loads considered in heel slab of Retaining Walls?

- (i) Weight of the backing
- (ii) Dead load on heel slab
- (iii) Vertical component of lateral pressure acting on the heel slab
- (IV) Upward soil reaction

23. What is angle of internal friction ( $\Phi$ )?

The angle tangent of which is equal to the ratio of the maximum resistance to sliding on any internal plane to the normal pressure acting on the plane

24. What are the stabilities has to be checked, designing Retaining Walls? (Dec 2009)

1. Stability against over turning
2. Stability against sliding

25. What are the points to be noted in the design of Cantilever Retaining Wall?

1. The thickness of the stem may be kept the same throughout the height to provide adequate dead load
2. The base slab may be made about 100mm thicker than stem
3. The width of the base slab may be kept about 0.7 to 0.8 times the total height of the wall
4. It may most probably require a key to be provided to have a safe factor of safety against sliding

26. What is Counter fort Retaining Wall? Explain its component?

Retaining Wall over 6m in height are usually made of Counter fort type.

1. Upright slab : its design as a continuous slab spanning horizontally on the Counter fort subjected to lateral earth pressure
2. Base slab: the width of the base slab may be taken as  $0.6H$  to  $0.7H$  where  $H$  = over all height of the retaining wall.
3. Heel slab: the Heel slab should be designed as a continuous horizontal slab with counter fort as the supports.

27. What are the loads acting on the heel slab of the Counter fort Retaining Wall?

1. Dead load of the strip
2. Weight of the earth above the strip
3. Vertical components of the lateral pressure in the case of the earth surcharged at an angle.

28. What is spacing of the Counter fort in Counter fort Retaining Wall?

The spacing the Counter fort is 3m to 3.5m

**EXPECTED 16 MARKS QUESTIONS:**

1. Design a cantilever retaining wall to retain earth embankment 4m high above G.L. The density of earth is  $18\text{KN} / \text{m}^3$  and its angle of repose is 30 degrees. The embankment is horizontal at its top. The safe bearing capacity of the soil may be taken as  $200\text{KN} / \text{m}^2$  and the co-efficient of friction between the soil and concrete is 0.5. Adopt M20 grade of concrete and Fe 415 HYSD bars.
2. Design a counter fort retaining wall to suit the following data:  
Height of the wall = 6m  
SBC of the soil at site =  $160\text{KN} / \text{m}^2$   
Angle of internal friction = 33 degree  
Density of soil =  $16\text{KN} / \text{m}^3$   
Spacing of counter fort = 3m c / c  
Grade of concrete = M20  
Grade of steel = Fe 415 HYSD bars
3. Design the stem of a reinforced concrete cantilever type retaining wall to retain earth with the top of the wall to a height of 5m. The density of soil is  $14\text{KN}/\text{m}^3$  and the angle of repose is 30 degrees. Adopt M20 grade concrete and Fe 415 HYSD bars. Sketch the details of reinforcements in the retaining wall. Assume SBC of soil as  $180\text{KN} / \text{m}^2$ .
4. Design a cantilever type retaining wall to support a bank of earth above GL on the toe side of the wall. The backfill surface is inclined at an angle of 15 degrees with the horizontal. Assume that good soil for foundation at a depth of 1.25m below GL with a SBC of  $160\text{KN}/\text{m}^2$ . The granular soil in the backfill has a unit weight of  $16\text{KN}/\text{m}^3$  and an angle of shearing resistance of 30 degree. Assume co-efficient of friction between the soil and concrete to be 0.5  $f_{ck} = 20$  and  $f_y = 415\text{N}/\text{mm}^2$ .
5. Design a counter fort type retaining wall to suit the following data:  
Safe bearing capacity of soil =  $200\text{KN}/\text{m}^2$   
Height of the soil above GL = 7m  
Unit weight of soil =  $18\text{KN}/\text{m}^2$   
Angle of internal friction =  $30^\circ$   
Spacing of counter fort = 3m centers  
Grade of concrete = M20  
Grade of steel = Fe 415 HYSD bars
6. A reinforced concrete retaining wall of cantilever type is required to retain a granular fill to a height of 4m above GL with the top of the wall. The depth of foundation may be taken as 1.2m below G.L. The unit weight of fill is  $14\text{KN} / \text{m}^3$  and angle of internal friction is  $30^\circ$ . The Safe bearing capacity of soil is  $200\text{KN}/\text{m}^2$ . The base slab is to be 400mm thick. Adopt Grade of concrete = M20, Grade of steel = Fe 415 HYSD bars.
7. A cantilever type retaining wall is to be designed to retain an earthen embankment with a horizontal top 4m above G.L. Density of soil =  $18\text{KN}/\text{m}^3$ . Angle of repose = 30degree. SBC of soil =  $200\text{KN}/\text{m}^2$ . Co-efficient of friction between the soil and concrete = .5. Adopt Grade of concrete = M20, Grade of steel = Fe 415 HYSD bars.

**UNIT -II WATER TANKS**

**EXPECTED TWO MARKS**

1. Define Domes

A dome consists of a shell which is generated by the revolution of a geometrical curve about a horizontal axis. A conical dome is obtained by revolving a triangle about a central vertical axis. Domes are used to roof circular areas. They are used in buildings and water tanks.

2. What are the different types of Domes?

- (a) Spherical domes  
(b) Conical domes

3. What are the stresses acting on domes?

- (a) Meridional thrust  
(b) Hoop stress

4. Define Meridional thrust (T)

For the purpose of analysis, let us consider the domes as formed by a series of horizontal rings of decreasing diameters placed one above the other. Hence, when we apply a load on a dome, it is resisted by its horizontal rings. There will thus be a thrust of one ring on the other. This thrust is called Meridional thrust.

5. Define Hoop stress (f)

Let "T" be the thrust per unit run on the ring. The horizontal component of this thrust will produce a hoop tension.

6. What is the formula for Meridional thrust of the spherical domes?

$$T = [wR / (1 + \cos\theta)] + [W / 2\pi R \cdot \sin^2\theta]$$

7. What is the formula for Hoop stress of the spherical domes?

$$f = wR / t (\cos\theta - 1 / (1 + \cos\theta)) + [W / 2\pi R t \cdot \sin^2\theta]$$

8. What is the formula for Meridional thrust of the conical domes?  $Wh/t \tan^2\theta$

$$T = [wh / 2 \cdot \sec^2 \theta] + [W \sec \theta / (2\pi h \cdot \tan \theta)]$$

9. What is the formula for Hoop stress of the conical domes?

$$f = Wh / t \tan^2\theta$$

10. Define water tank

A water tank is used to store water to tide over the daily requirements.



11. What are the classifications based on under three heads?

- (I) Tanks Resisting On Ground
- (ii) Elevated Tanks Supported On Staging
- (iii) Underground Water Tanks

12. What are the classifications based on shape point of view?

- (I) Circular tank
- (ii) Rectangular tank
- (iii) Spherical tank
- (iv) Circular tank with conical bottom

13. What are the joints in water tanks?

- (a) Movement joints
  - (i) Contraction joints
  - (ii) Expansion joints
  - (iii) Sliding joints
- (b) Construction joints
- (c) Temporary joints

14. Define underground water tank?

Under ground water tank are used in water purification purpose. The walls of such tanks are subjected to water pressure due to water stored in the tank and earth pressure.

15. What are the effects in circular water tank due to wall restrained at the base?

- (a) Deformation of wall
- (b) Load distribution
- (c) Approximate B.M

16. What are the methods available for analysis of circular water tank?

- (I) Dr.Reissner's method
- (ii) Carpenter's simplification of Dr.Reissner's method

17. What are the steps involved in design of circular tanks?

- a) The domes
- b) Ring beam supporting the domes
- c) Cylindrical wall
- d) Ring beam supporting the domes
- e) Conical slab
- f) Floor of the tank
- g) The ring girder
- h) Column
- i) Foundation

18. What are the components of the water tank?

- a) Roof slab
- b) Roof beams
- c) Floor slab
- d) Vertical wall
- e) Floor beams
- f) Columns
- g) Braces
- h) Foundation

19. What are the components to design the small over head circular tanks?

- a) Cylindrical wall
- b) Circular slab
- c) Supporting beams and columns

20. What are the conditions has to be considered while designing the underground water tank?

- a) Tank is full and the surrounding soil is dry
- b) Tank is empty and the surrounding soil is water logged
- c) Tank is full and surrounding soil is water logged
- d) Tank is dry surrounding soil is dry

21. What are the critical cases has to be considered while designing the underground water tank?

- a) When the tank is full
- b) When the tank is empty

22. Define conical domes?

The thrust and hoop stress in the conical domes can be determined on lines similar to those of the spherical dome.

23. Define domes with openings.

If an opening is provided in a dome sufficient trimming reinforcement should be provided all round the opening. The reinforcement reaching the opening should be wall anchored to the trimming reinforcement.

24. What are the different loading conditions available in domes?

- a) Uniformly distributed load of 'w' per unit area of the dome surface
- b) Concentrated load on the crown of the domes

25. Define ring beams and its advantages

Often the ring beam at the base is made by thickening the edges and providing adequate hoop steel to resist the hoop tension.

- a) Sometimes no thickening of the edge may become necessary and the requisition amount of hoop steel will be sufficient
- b) Often a ring beam section may be based of an architectural consideration
- c) A minimum of 0.3% of gross area shall be provided as the reinforced in each principal direction for the dome section

**EXPECTED 16 MARKS QUESTIONS:**

1. A reinforced concrete dome of 6m base diameter with a rise of 1.25m is to be designed for a water tank. The uniformly distributed live load including finishes on dome may be taken as  $2\text{KN/m}^2$ . Adopt M20 concrete and grade I steel, design the dome and ring beam. Permissible tensile stress in steel =  $100\text{N/mm}^2$ .
2. Design a circular water tank with a flexible base for a capacity of 500,000 liters. The depth of water is to be 4m. Free board = 200mm. Use M20 concrete and grade I steel. Permissible direct tensile stress in concrete =  $1.2\text{N/mm}^2$ . Permissible direct tensile stress in steel =  $100\text{ N/mm}^2$ . Sketch the details of reinforcements in tank walls.
3. Design a circular water tank with a fixed base for a capacity of 400,000 liters. The depth of water is to be 4m. Free board = 200mm. Use M20 concrete and grade I steel. Permissible direct tensile stress in concrete =  $1.2\text{N/mm}^2$ . Permissible direct tensile stress in steel =  $100\text{ N/mm}^2$ . Sketch the details of reinforcements in tank walls. Adopt IS code tables for co-efficient.
4. A rectangular RC water tank with an open top is required to store 80,000 liters of water. The inside dimensions of tank may be taken as  $6\text{m} * 4\text{m}$ . The tank rests on walls on all four sides. Design the side walls of the tank using M20 concrete and grade I steel.
5. A reinforced concrete water tank resting on ground is  $6\text{m} * 2\text{m}$  with a maximum depth of 2.5m. Using M20 concrete and grade I steel. Design the tank walls.
6. Design an over head flat bottomed RCC cylindrical water tank to store 100Kl of water. The top of the tank is covered with a dome. Height of staging = 12m above GL. Provide 2m depth of foundation. Intensity of wind pressure may be taken as  $\text{KN/m}^2$ . SBC of the soil at site is  $100\text{ KN/m}^2$ . Adopt M20 concrete and grade I steel. design the following:
  - (a) Size of tank
  - (b) Ring beam at junction of dome and side walls
  - (c) side wall of tank
  - (d) bottom ring girder
  - (e) Tank floor slab
  - (f) Bracing at 4m intervals
  - (g) RC columns assuming six column supports
  - (h) Foundation for the tank.
7. Design the side walls of a square of RCC tank of capacity 70,000 liters of water. Depth of water in the tank = 2.8m. Free board = 0.2m. Adopt M20 concrete and grade I steel. Tensile stresses in steel limited to  $100\text{N/mm}^2$  at water face and  $125\text{N/mm}^2$  away from face. Sketch the details of reinforcements in the walls of the tank.
8. Design an RC tank of internal dimensions  $10\text{m} * 3\text{m} * 3\text{m}$ . The tank is to be provided under ground. The soil surrounding the tank is likely to get wet. Angle of repose of soil in dry state is  $30^\circ$  and in wet state is  $6^\circ$ . Soil weight =  $20\text{KN/m}^3$ . Adopt M20 concrete and grade I steel.

**UNIT -3 SELECTED TOPICS**

**EXPECTED TWO MARKS**

1. Define Stair Cases

Staircase flights are generally designed as slabs spanning between wall supports or landing beams or as cantilever from a longitudinal inclined beam. The staircase fulfills the function of access between the various floors in the building. Generally the flight steps consists of one or more landings between the floor levels.

2. What are the structural components of the Staircases?

- a) TREAD: The horizontal portion of a step where the foot rests is referred to as tread 250 to 300 mm is the typical dimensions of a tread.
- b) RISER: It is the vertical distance between the adjacent treads or the vertical projection of the step with the value of 150 to 190 mm depending upon the type of building. The width of the stairs is generally 1 to 1.5 m and in any case not less than 850mm. Public buildings should be provided with larger widths to facilitate free passage to users and prevent overcrowding.
- c) GOING: It is the horizontal projection plan of an inclined flight of steps between the first and the last riser. A typical flight comprises two landings and one out going. The number of steps in a flight should not exceed 10 to 12.

3. Draw the various types of Stair Cases? And Explain its components

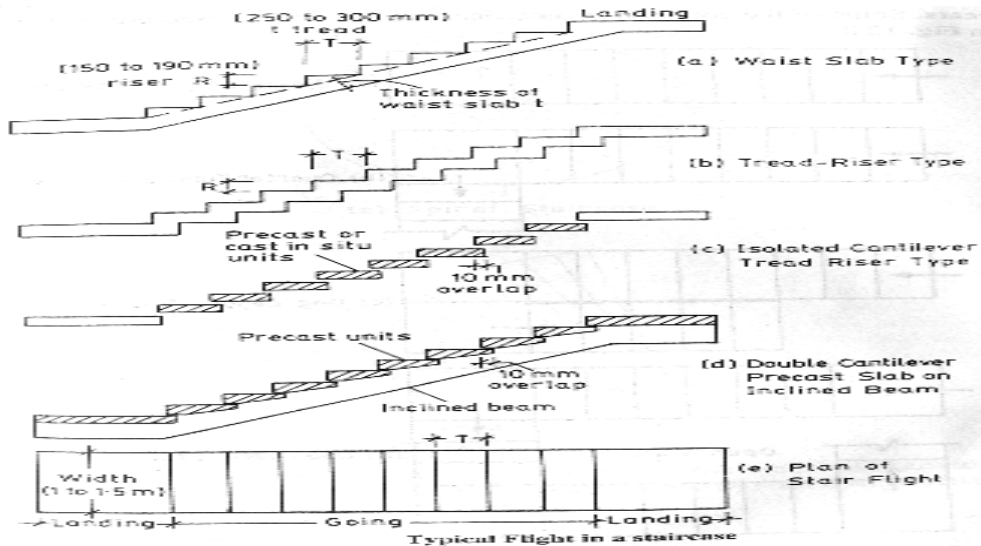

**Geometrical classification**

Aesthetic considerations have evolved a wide variety of staircases over the years. Some of the common geometrical configurations used are compiled

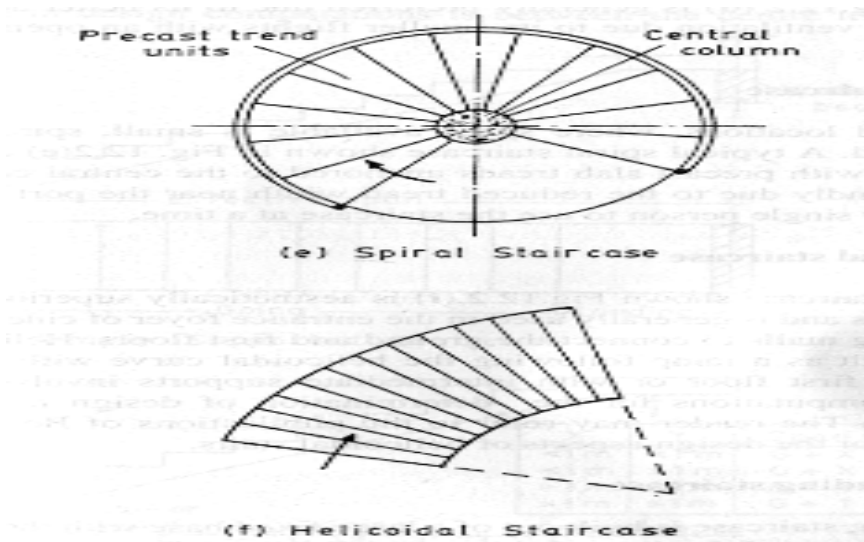
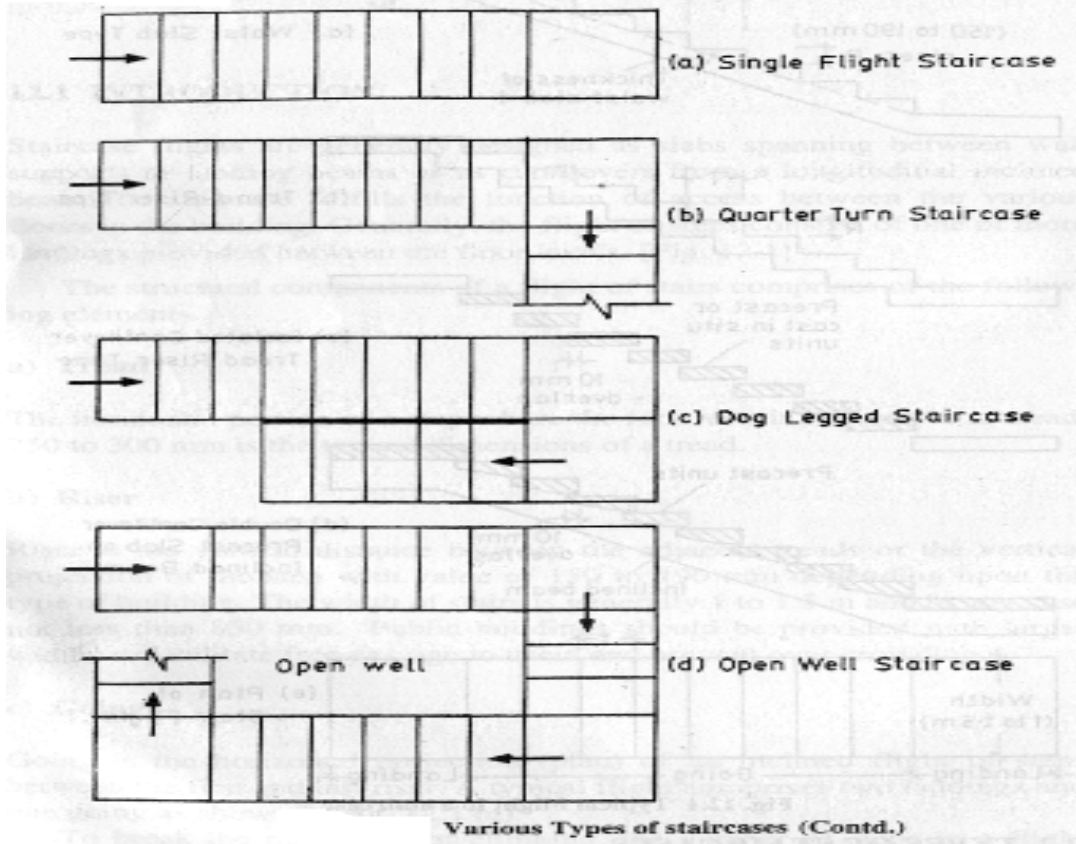

4. Explain structural behaviors of Stair Cases?

Staircases can be grouped depending upon the support conditions and the direction of major bending of the slab component under the following categories.

- a) Staircase slab spanning longitudinally ( along the sloping line)
- b) Staircase slab spanning transversely ( Slab width wise with central or side supports)

5. How does loading done in Stair Cases? Explain with neat sketch?

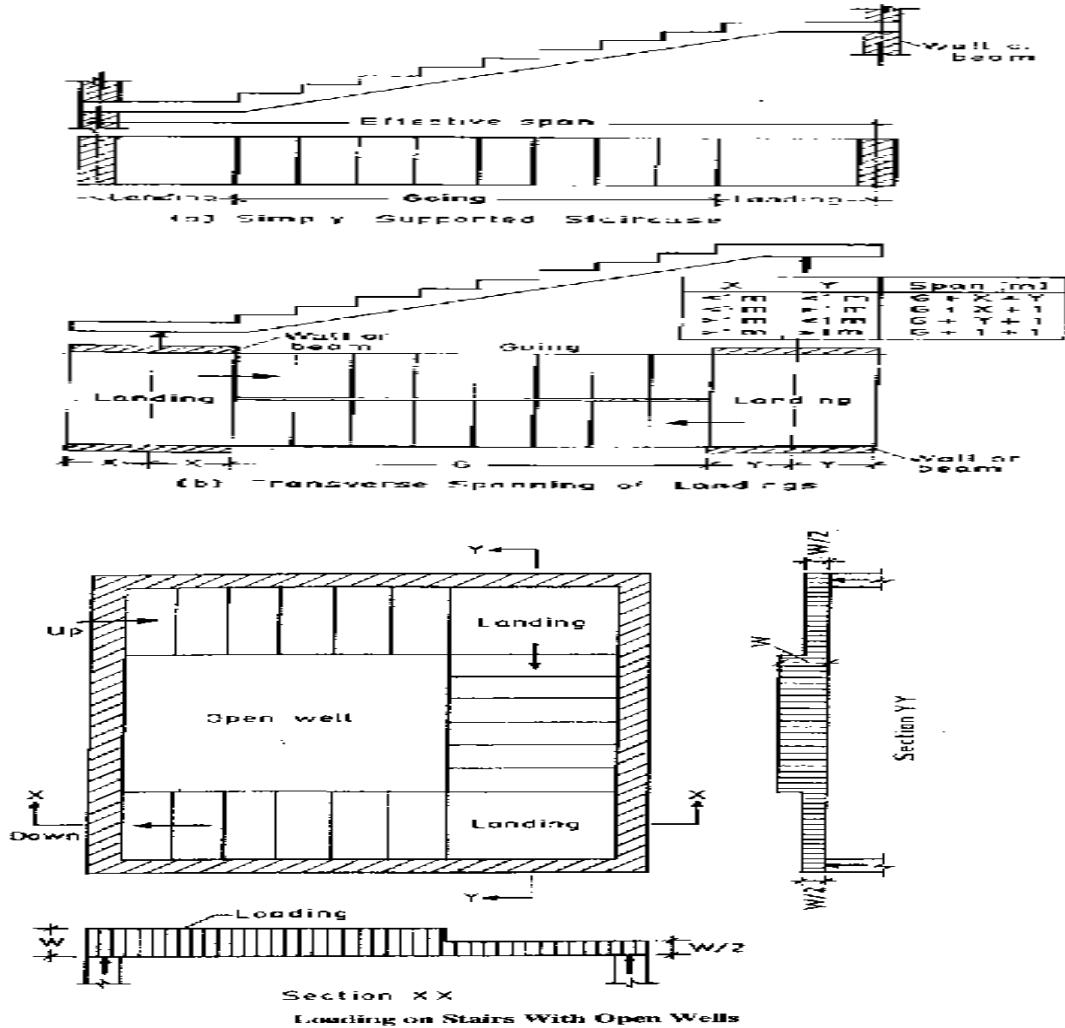

6. What are the loads acting on Staircases? Explain.

a) DEAD LOADS:

- I) Self weight of stair slab concrete which includes the waist slab, tread – riser etc..
- II) Self weight of finishes ( 0.5 to 1 kN/m<sup>2</sup>)

b) LIVE LOADS: IS 875 part II specifies the load to be considered as UDL of intensity 5 kN/m<sup>2</sup> for public buildings and 3 kN/m<sup>2</sup> for residential building where the specified floor do not exceed 2 kN/m<sup>2</sup>, and the staircases are not liable for overcrowding.

7. Define flat slab.

A flat slab is a reinforced concrete slab supported directly over columns without beams generally used when headroom is limited such as in cellars and warehouses.

8. What are the End Conditions in Staircases?

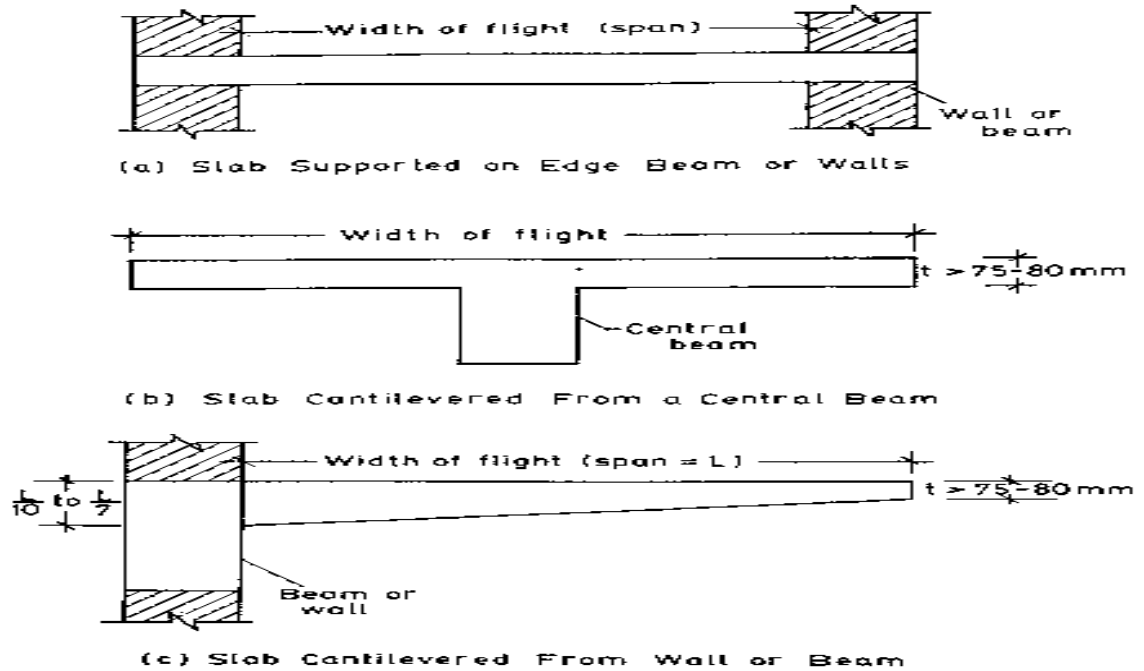

9. What are panel divisions? Explain them

The flat slab panel is generally divided into column strip and middle strip.

- Panel:** Panel is that part of the slab bounded on each of its four sides by the centre line of columns or centre lines of adjacent spans.
- Column Strip:** Column strip is a design strip having a width of  $0.25 L_2$  but not greater than  $0.25 L_2$ , on each side of the column centre line where  $L_1$  is the span in the direction, moments are being determined measured centre to centre of supports and  $L_2$  is the span transverse to  $L_1$  measured centre to centre of supports.
- Middle Strip:** Middle strip is a design strip bounded on each of its opposite sides by the column strip.

Fig shows the division of flat slab into column and middle strips.

10. Draw the load effects in a Staircase?

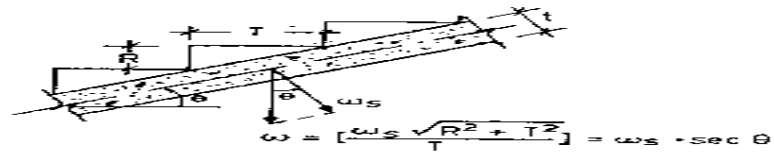

(a) Self Weight of Sloping Slab

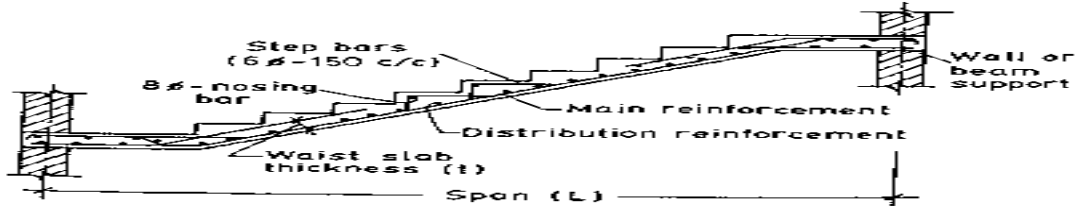

(b) Reinforcement Detailing in Staircase Spanning Longitudinally

**Load Effects and Detailing in Waist Slabs**

11. What are different types of Flat Slab?

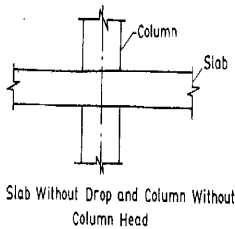

Slab Without Drop and Column Without Column Head

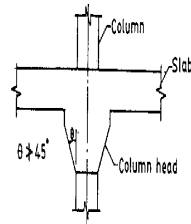

$\theta > 45^\circ$

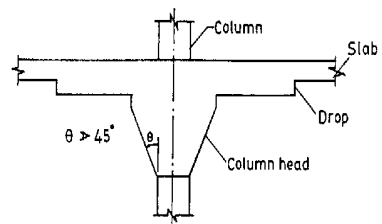

$\theta > 45^\circ$

**Slab Without Drop and Column With Column Head**

**Slab With Drop and Column With Column Head**

12. Draw the Division of Flat Slab in to Column and Middle Strips?

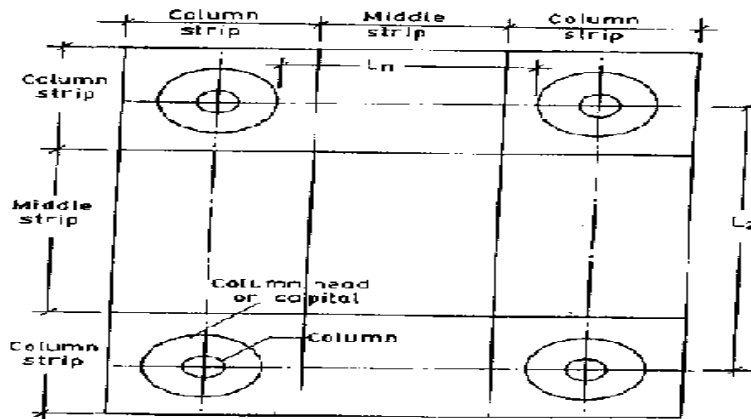

**Division of Flat Slab into column and Middle Strips**



13. What is the proportioning of slab thickness, drop panel and column panel?

**a) Thickness of Flat slab**

The thickness of flat slab depends upon the span / effective depth ratio which is specified as 40 for two-way slabs. However the IS: 456 code permits a reduction factor of 0.9 resulting in a span / effective depth ratio of 36 for flat slabs. However the longer span should be considered in the computations. The minimum thickness of a flat slab is 125 mm.

**b) Drops**

The drop panel is formed by increasing the thickness of slab in the vicinity of the supporting column. The main purpose of providing drops is to reduce the shear stress around the column supports. Since the moments in the column strip are higher than in middle strips, drops help to reduce the steel requirement to resist the negative moments at the column supports.

**c) Column Head**

The column head or capital located by flaring of the column at the top is primarily intended to increase the punching shear strength of the slab. The IS: 456 Code clause (C1.31.2.3) specifies the useful portion of the column capital as that which lies within the largest circular cone or pyramid that has a vertex angle of 90° and can be included entirely within the outlines of the column and column head.

14. Write about the Direct Design Method?

**Direct Design Method**

The direct design method facilitates the computation of positive and negative design moments under design loads at critical sections in the slab using empirical moment coefficients. However, the code (C1.21.4.1) specifies that the following conditions must be satisfied by the flat slab system for the application of the direct design method.

- a) There must be at least three continuous spans in each direction.
- b) The panels should be rectangular and the ratio of the longer span to the shorter span within a panel should not exceed 2
- c) The columns must not be offset by more than 10 percent of the span from either axis between centre lines of successive columns.
- d) The successive span lengths in each direction must not differ by more than one third of the longer span.
- e) The design live load must not exceed three times the design dead load.

15. What is Total Design Moment for a Span?

**Total Design Moment for a span**

In the direct design method, the total design moment for a span bounded laterally by the centre lines of the panel on each side of the centre line of supports is expressed as (C1.31.4.2.2)

$$M_o = \left( \frac{WL_n}{8} \right)$$

Where  $M_o$  = absolute sum of the positive and average negative bending moment in each direction.

$W$  = total design load covered on an area  $L_2 L_n$

$L_n$  = clear span extending from face to face of columns, capitals brackets or walls, but not less than  $0.65 L_1$

$L_1$  = length of span in the direction of  $M_o$

$L_2$  = span length transverse to  $L_1$

16. What are moments in interior panel of a Flat Slab?

**a) Moments in Interior Panel**

Type of Moment	Bending Moment Distribution (Percent of $M_o$ )	
	Column Strip	Middle Strip
Negative Moment	$(0.65 \times 0.75) = 49\%$	15%
Positive Moment	$(0.35 \times 0.60) = 21\%$	15%

17. What are the design moments in Flat Slab?

The expressions for  $M_o$  is computed as the maximum mid span static moment in an equivalent simply supported span  $L_n$ , subjected to a uniformly distributed total load  $W = w (L_2 L_n)$  where  $L_2 L_n$  is the effective panel area on which the unit load 'w' acts.

According to IS: 456-2000 Clauses 31.4.3.2, the total moment  $M_o$  in the panel is distributed to the column and middle strips in the following proportions.

18. What are moments in exterior panel of a Flat Slab?

The total design moment  $M_o$  is distributed in the following proportions.

$$\text{Interior Negative Design Moment} = 0.75 - \left[ \frac{0.10}{1 + (1/\alpha_c)} \right]$$

$$\text{Exterior Negative Design Moment} = \left[ \frac{0.65}{1 + (1/\alpha_c)} \right]$$

$$\text{Positive Design Moment} = 0.63 - \left[ \frac{0.28}{1 + (1/\alpha_c)} \right]$$

Where  $\alpha_c$  = Ratio of flexural stiffness of exterior columns to the flexural stiffness of the slab at a joint taken in the direction, moments are being determined and is given by

Where  $\alpha_c = [\sum K_c / K_s]$   
 $\sum K_c$  = Sum of the flexural stiffness of the columns meeting at the joint and

$K_s$  = Flexural stiffness of the slab, expressed as moment per unit rotation.

At an exterior support, the column strip must be designed to resist the total negative moment in the panel at that support.

19. What is Equivalent Frame Method in Flat Slab?

**Equivalent Frame Method**

The structure is analysed as a continuous frame with the following assumptions.

- a) The structure is considered to be made up of equivalent frames longitudinally and transversely consisting of row of columns and strip of slab with a width equal to the distance between the centre lines of the panel on each side of the row of columns.
- b) Each frame is analysed by any established method like moment distribution or any other suitable method. Each strip of floor and roof may be analysed as a separate frame with the columns above and below assumed fixed at their extremities.
- c) The relative stiffness is computed by assuming gross cross section of the concrete alone in the calculation of the moment of inertia.
- d) Any variation of moment of inertia along the axis of the slab on account of provision of drops should be considered. In the case of recessed or coffered slab which is made solid in the region of the columns, the stiffening effect may be ignored provided the solid part of the slab does not extend more than 0.15 Lef into the span measured from the centre line of the columns. The stiffening effect of flared column heads may be ignored.

20. What are shear availability in Flat Slab?

**Shear in Flat Slab**

In the case of flat slabs, the critical section for shear is at a distance  $(d/2)$  from the periphery of the column / capital / drop panel, perpendicular to the plane of the slab where 'd' is the effective depth of the section. The shape in plan is geometrically similar to the support immediately below the slab.

The nominal shear stress in flat slabs is computed as  $(V/b_o \cdot d)$  where V is the shear force due to design load and  $b_o$  is the periphery of the critical section and d is the effective depth.

When shear reinforcement is not provided, the calculated shear stress at the critical section shall not exceed  $k_s \cdot \tau_c$  where

$$k_s = (0.5 + \beta_c) \text{ but not greater than } 1.$$

$$\beta_c = \text{Ratio of short side to long side of the column / capital and}$$

$$\tau_c = 0.25 \sqrt{f_{ck}} \text{ in limit state method of design and } 0.16 \sqrt{f_{ck}} \text{ in working stress method of design.}$$

21. Define Concrete Wall?

When the steel percentage is low (0.4%), the wall is assumed to carry the whole load without the help of steel reinforcement and it's called as plain concrete wall

22. What is Slenderness ratio of the wall?

Effective height/ Effective thickness

Effective length/ Effective thickness whichever is less.

23. What is short & long column?

Effective height/ Effective thickness do not exceed 12.

If it exceeds (or) equals (or) equals (or) more than 12, it is considered as long (or) slender column

24. What are braced and unbraced walls?

Braced Walls: the legs are interconnected

Unbraced Walls: the legs are not connected

25. What are cases available in R.C wall?

Case (I) Design of short braced R.C wall

Case (II) Design of slender braced R.C wall

Case (III) Design of short unbraced R.C wall

26. Define Box Culvert.

These are provided for conveying water to serve the following requirements

(I) To serve as means for a cross drainage

(II) To provide a supporting slab for road way under which the cross drainage flows

27. What are cases available in Box Culvert?

Case (I) when the top slab carries the dead and live load and culvert is empty

Case (II) when the top slab carries the dead and live load and culvert is full of water

Case (III) when the sides of culvert do not carry live load and culvert is full of water.

EXPECTED 16 MARKS QUESTIONS:

1. Explain the types of staircase with neat sketch.
2. Design one of the flights of a dog legged stairs between the landing beams using the following data:  
Type of staircase: Dog legged staircase with waist slab, treads and risers  
  
No. of steps in the flight: 10  
  
Thread T = 300mm  
  
Rise R = 150mm  
  
Width of landing beams = 300mm  
  
Grade of concrete = M20  
  
Grade of steel = Fe415.  
  
The general arrangement of stair case in an multistory housing complex. The risers are 150mm and treads are 250mm. The stair case is embedded into the wall by 200mm. The height between the floors is 3m. The service live load is 3 KN/m<sup>2</sup>. Adopt Grade of concrete = M20 & Grade of steel = Fe415. Design the staircase flight and draw a longitudinal section showing the details of reinforcements in the flight of the staircase.
3. Design a tread-riser type staircase flight between the landings. The landings slab is supported on adjacent edges. Adopt a live load of 5KN/m<sup>2</sup>. Adopt Grade of concrete = M20 & Grade of steel = Fe415.
4. A staircase flight is made up of independent tread slabs cantilevered from a reinforced concrete wall. Tread = 300mm risers = 150mm. Width of flight = 1.5m. Design the cantilever slab using M20 grade concrete and Fe415 HYSD bars. Assume LL = 5KN/m<sup>2</sup>.
5. Design the interior panel of a flat slab with drops for an office floor to suit the following data:  
Size of office floor = 25 x 25m  
  
Size of panels = 5m x 5m  
  
Loading class = 4 KN/m<sup>2</sup>  
  
Adopt Grade of concrete = M20 & Grade of steel = Fe415.
6. Design the typical interior panel of a flat slab floor for a public bank building with panels of size 4m x 6m to support a live load of 4KN/m<sup>2</sup>. Using Grade of concrete = M20 & Grade of steel = Fe415. Sketch the details of reinforcement in the slabs.

7. The foundation for a structure consists of 10 piles to carry a load of 6000KN. The piles are spaced 1.5m centers. They are driven through a hard stratum available at a depth of 6m. Design one pile and sketch the details of the reinforcements. Grade of concrete = M20 & Grade of steel = Fe415.
  
8. Explain the design procedure for mat foundation.
  
9. Explain the design procedure for flat slab.
  
10. Explain the design procedure for staircase.
  
11. Explain the principles, types and methods of pre stressed concrete.
  
12. Explain the advantages and disadvantages of prestressed concrete bridges.

UNIT -IV YIELD LINE THEORY

EXPECTED TWO MARKS

1. Define Yield Line Theory.

The failure of reinforced concrete slabs of different shapes such as square, rectangular, circular with different types of edge conditions is preceded by a characteristic pattern of cracks which are generally referred to as yield lines which are characteristic of the shape of slab, type of loading and edge conditions. The yield line theory was innovated by a Danish engineer

Ingerslav<sup>73</sup>, and was considerably improved and advanced by Johanssen<sup>74, 75</sup>. In the case of slabs the computation of ultimate loads is really complicated and is a challenge to the research workers and designers.

The determination of ultimate loads on slabs based on yield line theory has been further extended by Wood<sup>76, 77</sup> and Jones<sup>78</sup> of Great Britain. Shukla's<sup>79</sup> hand book published by SERC is also a useful reference for the

2. What is design of slab using Yield Line Theory?

design of slabs using the yield line theory. The Indian standard code IS: 456-2000 specifies that two way slabs carrying uniformly distributed loads may be designed by any acceptable theory. The most generally used elastic methods are based on Poteau's or Westergaard's theory<sup>80, 81</sup> and the ultimate load methods are based on Johanssen's yield line theory and Hillerborg's<sup>82</sup> strip method of design. The ultimate load methods have been used by the author<sup>83, 84</sup> for the design of different types of slabs.

3. What are the Characteristics of Yield Line Theory of Slab? (Dec 2007)

**Characteristic Features of yield lines**

The typical crack pattern (yield lines) developed in an isotropically reinforced square slab is shown in Fig. 9.12. As the load is gradually increased on the slab, the region of highest moment will yield first and the yield lines are propagated until they reach the boundaries of the slab. The final failure will take place by the rotation of the slab elements about the axes of rotation which are usually the supporting edges of the slab.

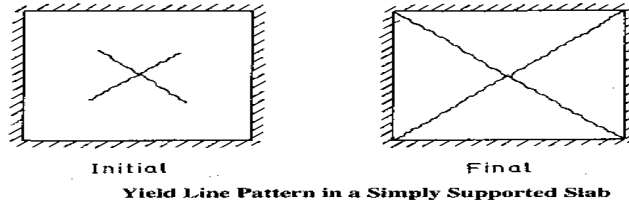

4. What are the points to be considered for Yield Line Theory of Slab?

It is important to note that for the complete yield line pattern to develop, the slab must be under reinforced so that sufficient rotation capacity is available for the initiation and propagation of the yield lines.

The following characteristic features of yield lines are helpful in selecting a possible yield line mechanism in a typical slab.

- a) Yield lines end at the supporting edges of the slab
- b) Yield lines are straight
- c) A yield line or yield line produced, passes through the intersection of the axes of rotation of adjacent slab elements.
- d) Axes of rotation generally lie along lines of supports and pass over any columns.

5. What are the followed for the End conditions of Yield Line Theory of Slab?

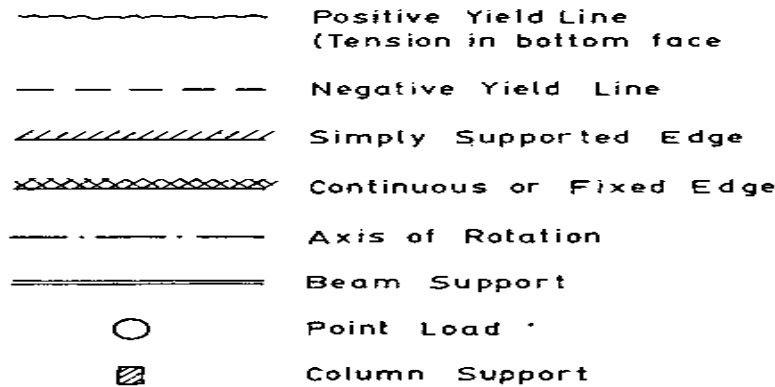

6. How to calculate the moments in Yield Line Theory of Slab?

**Yield Moments**

When the yield lines form at right angles to the direction of the reinforcement The yield or ultimate moments is computed by considering the slab section as under reinforced.

According to IS: 456-2000, the yield or ultimate moment is expressed as

$$m = M_u = 0.87 f_y A_{st} d \left[ \frac{1 - A_{st} f_y}{b d f_{ck}} \right]$$



7. Draw the Typical Yield Line Pattern in Reinforced Concrete Slab? (Dec2009)

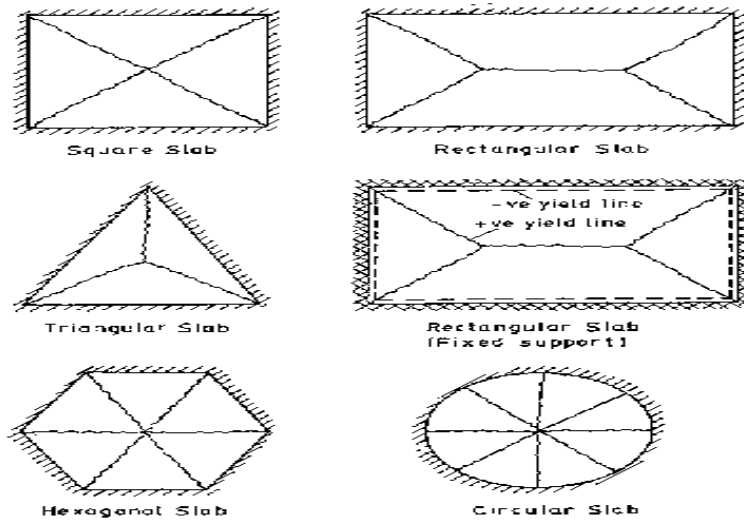

8. Draw the Yield Moments for three Conditions?

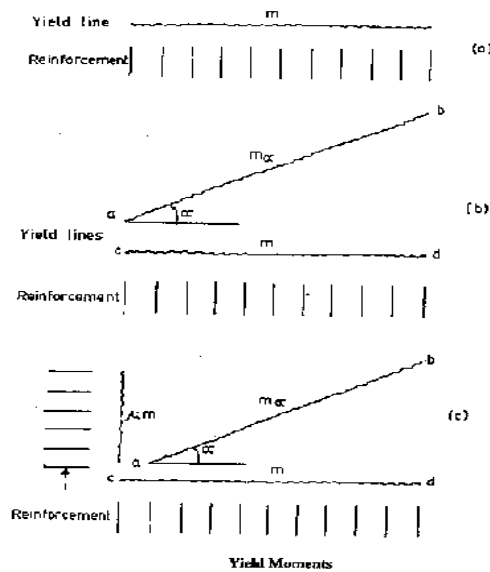

9. What are Methods for Determining the Ultimate Load Carrying Capacity of Slab?

They are based on two Principles:

1. Virtual work
2. Equilibrium

10. What is moment for Square Slab with simply supported Beam with UDL?

$$m = \left( \frac{wL^2}{24} \right)$$

11. Draw the Yield Line Pattern in Square Slab for S.S Beam?

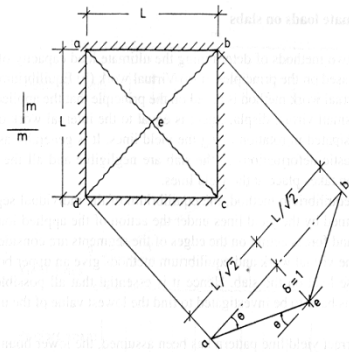

Yield Line Pattern in a Square Slab (Simply Supported)

12. What is moment for Square Slab fixed on all the edges and subjected to UDL?

$$m = \left( \frac{wL^2}{48} \right)$$

13. Draw the Yield Line Pattern for Square Slab fixed on all the edges and subjected to UDL?

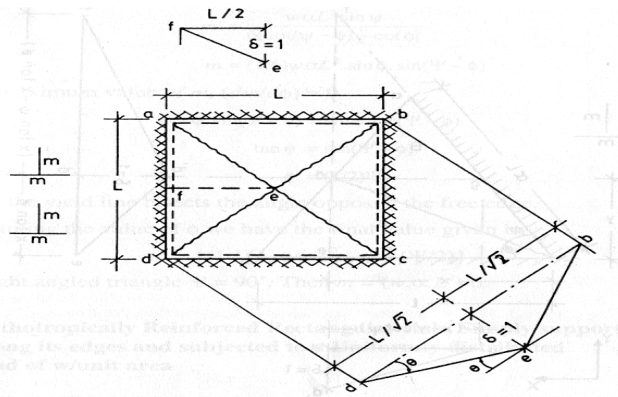

14. What is moment for triangular slab S.S on adjacent edges and subjected to UDL?

$$m = \left( \frac{1}{6} \right) w \alpha L^2 \cdot \sin^2 (\Psi/2)$$

In a right angled triangle  $\Psi = 90^\circ$ . Then  $m = (w \cdot \alpha \cdot L^2) / 6$

15. Draw the Yield Line Pattern for triangular slab S.S on adjacent edges and subjected to UDL?

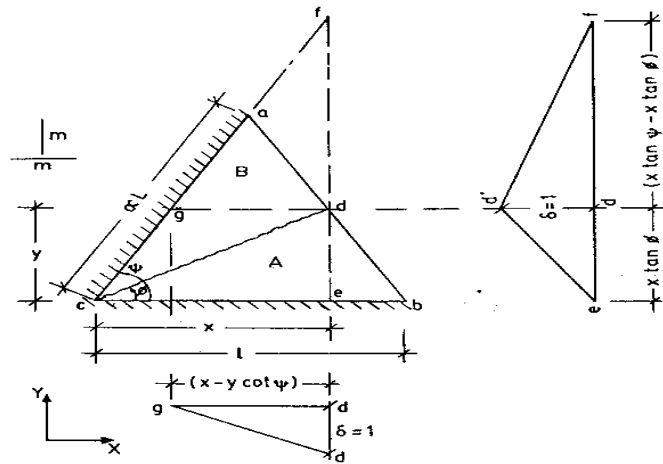

16. What is moment for reinforced rectangular slab S.S along its edges subjected to a UDL of w/Unit area?

$$m = \left( \frac{w\alpha^2 L^2}{24} \right) \left[ \sqrt{3 + \mu\alpha^2} - \mu\alpha^2 \right]^2$$

17. Draw the yield line moment for reinforced rectangular slab S.S along its edges subjected to a UDL of w/Unit area?

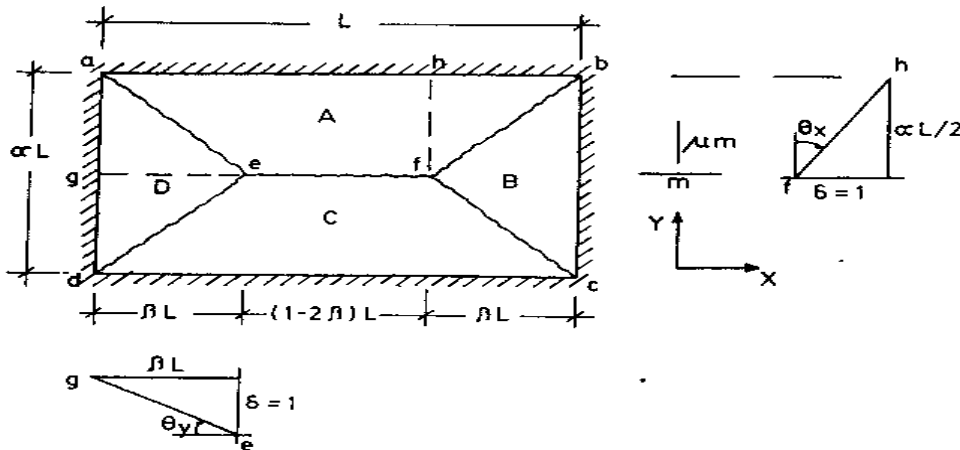

18. What is moment for Reinforced circular slab, S.S all round and UDL?

$$m = \left( \frac{w r^2}{6} \right)$$

19. Draw the yield line moment for Reinforced circular slab, S.S all round and UDL? (Dec 2010)

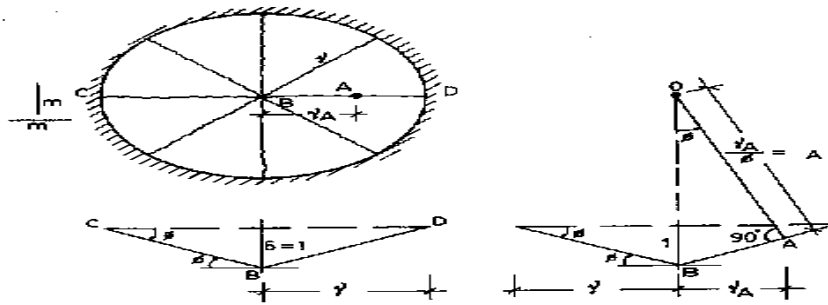

20. Write down the formula for moment by equilibrium method for square slab Reinforced to a UDL?

$$m = \left( \frac{wL^2}{24} \right)$$

21. Write down the formula for moment by equilibrium method for rectangular slab Reinforced to a UDL?

$$m = \left[ \left( \frac{w\alpha^2 \cdot L^2}{24} \right) (3 - 4\beta) \right]$$

Taking moments about be for element B

$$m = \left( \frac{w\alpha^2 L^2}{24} \right) \left[ \sqrt{(3 + \mu\alpha^2)} - \alpha\sqrt{\mu} \right]^2$$

22. Draw the yield line moment for Reinforced by equilibrium method for rectangular slab Reinforced to a UDL?

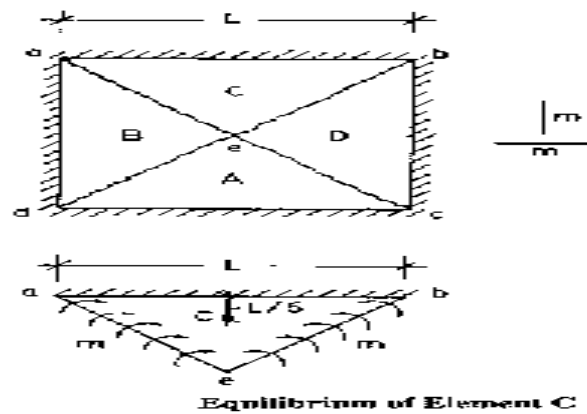

23. Draw the yield line moment for Reinforced by equilibrium method for rectangular slab?

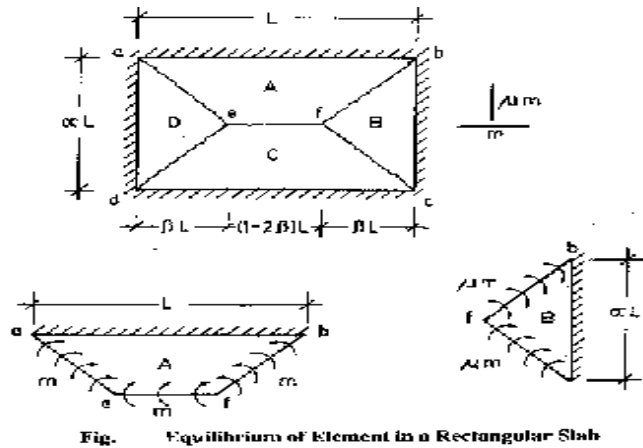

24. Write down the formula for moment by equilibrium method for hexonal slab subjected to UDL?

$$m = \left( \frac{w.L^2}{8} \right)$$

EXPECTED 16 MARK QUESTIONS:

1. Define yield line and explain characteristic features of yield line.
3. Derive the yield analysis by virtual work method for square slab.
4. Derive the yield analysis by virtual work method for rectangular slab.
5. Derive the yield analysis by virtual work method for circular slab.
6. Derive the yield analysis by virtual work method for triangular slab.
7. Design a SS square slab of 4.5m side length to support a service live load of 4KN/m<sup>2</sup>. Adopt M20 grade concrete and Fe 415 HYSD bars. Assume load factors according to IS code 456 2000 standards.

8. Design a rectangular slab by 5m x 4m in size and simply supported at the edges to support a service load of 4KN/m<sup>2</sup>. Assume coefficient of orthography  $\mu = 0.7$ . Adopt M20 grade concrete and Fe 415 HYSD bars.
9. A right angled triangle slab is simply supported at the adjacent edges AB and BC. The side AB= 4m and BC = 3m and CA = 5m. The slab is isotrophically reinforced with 10mm diameter bars at 100mm centers both ways at an average effective depth of 120mm. The overall depth of the slab is 150mm. If M20 grade concrete and Fe 415 HYSD bars, Estimate the safe permissible service live load on the slab.
10. Design a circular slab of diameter 4m which is simply supported at the edges. Adopt service live load as 4 KN/m<sup>2</sup> and M20 grade of concrete with Fe 415 HYSD bars. Assume load factors according to IS 456 – 2000 code.
11. A two way RCC slab is rectangular having a size of 4m x 5m with two longer edges fixed in position and the two shorter edges are simply supported. Derive the relation between moment capacity of slab and ultimate load by first principles and hence design the slab for a working live load of 3KN/m<sup>2</sup> by yield line theory. Assume  $\mu = 0.8$ . Adopt M15 grade concrete and HYSD bars.
12. A uniformly loaded isotrophically reinforced concrete square slab is simply supported on three sides and unsupported on the fourth. If  $w$  = load per unit area at collapse of slab and  $m$  = positive plastic moment per unit width, show that for the yield line pattern.
13. A rectangular slab 4.5 x 6.5m is SS at the edges. The coefficient of orthography  $\mu = 0.75$ . If the ultimate design load = 12KN/m<sup>2</sup>, estimate the ultimate moment capacity of the slab in the shorter span direction by derive the following expression:  
$$w = (24 m / Ly^2) (\mu / \tan^2\theta)$$
14. A square slab of 3m side length is SS along the edges and carries an udl of 30KN/m<sup>2</sup> including its own weight. If the slab is reinforced isotrophically to give an ultimate MR = 20KN.m/m, calculate the magnitude of the additional central point load required to cause collapse. Assume a pattern of simple diagonal yield lines.